

# INSTALLATION & USER INSTRUCTIONS

## WALL INSET ELECTRIC FIRE



Focal Point Fires Ltd  
Christchurch, Dorset BH23 2BT  
Tel: 01202 49933499330  
Fax: 01202 499326  
[www.focalpointfires.co.uk](http://www.focalpointfires.co.uk)  
e : [sales@focalpointfires.co.uk](mailto:sales@focalpointfires.co.uk)

Focal Point Fires Ltd  
RBK House, Irishtown, Athlone,  
Co. Westmeath, N37 XP52,  
Ireland Tel: 01202 499330  
Fax: 01202 499326  
[www.focalpointfires.co.uk](http://www.focalpointfires.co.uk)  
e: [sales@focalpointfires.co.uk](mailto:sales@focalpointfires.co.uk)

### MODELS COVERED BY THESE INSTRUCTIONS

**EF26-36A**  
**OREGON**

GB IE

CE  
UK  
CA



### OREGON LED ELECTRIC FIRE

# 3 YEAR GUARANTEE

SUBJECT TO TERMS & CONDITIONS

For details please see: [www.focalpointfires.co.uk](http://www.focalpointfires.co.uk) or telephone  
01202 588635 Option 4

This product is only suitable for well insulated spaces or occasional use.

Please note: Except where otherwise stated, all rights, including copyright in the text, images and layout of this booklet is owned by Focal Point Fires Ltd. You are not permitted to copy or adapt any of the content without the prior written permission of Focal Point Fires Ltd.

**All instructions must be handed to the user for safekeeping.**

Revision A - 04/23

© 2023 Focal Point Fires Ltd.

Section	Contents	Page No.	Section	Contents	Page No.
1.0	Important Notes	2	9.0	Fitting the Decorative Frame	7
2.0	Installation Requirements	3	10.0	Removing the Front Glass	8
3.0	Appliance Data	3	11.0	Operating the Appliance	8
4.0	Unpacking the Appliance	4	12.0	Safety Cut-Out System	12
5.0	Component Checklist	4	13.0	Cleaning and Maintenance Spares	12
6.0	Site Requirements	4	14.0	Servicing	12
7.0	Clearance to Combustibles	5	15.0	Troubleshoot Guide	13
8.0	Installing the Appliance	6	16.0	Guarantee - Terms and Conditions	13

## 1.0 IMPORTANT NOTES

### IMPORTANT - THESE INSTRUCTIONS SHOULD BE READ CAREFULLY AND RETAINED FOR FUTURE REFERENCE.

When using this electrical appliance, basic precautions should be followed to reduce the risk of fire, electric shock and injury to person, including the following:

- This heater must be used on an AC supply only and the voltage marked on the heater's rating label must correspond to the supply voltage.
- **DO NOT** switch the appliance on until it is properly installed as described in this manual.
- This appliance can be used by children aged from 8 years and above and persons with reduced physical, sensory or mental capabilities or lack of experience and knowledge if they have been given supervision or instruction concerning use of the appliance in a safe way and understand the hazards involved. Children shall not play with the appliance. Cleaning and user maintenance shall not be made by children without supervision. Children of less than 3 years should be kept away unless continuously supervised.
- Children aged from 3 years and less than 8 years shall only switch on/off the appliance provided that it has been placed or installed in its intended normal operating position and they have been given supervision or instruction concerning use of the appliance in a safe way and understand the hazards involved. Children aged from 3 years and less than 8 years shall not plug in, regulate and clean the appliance or perform user maintenance.
- **CAUTION:** Some parts of this product can become very hot and cause burns. Particular attention has to be given where children and vulnerable people are present.
- If the supply cord is damaged, it must be replaced by the manufacturer, its service agent or similarly qualified persons in order to avoid a hazard.
- The heater must not be located immediately below a socket-outlet.
- **DO NOT** use this heater in the immediate surroundings of a bath, a shower or a swimming pool.



- **WARNING:** In order to avoid overheating, do not cover the heater.
- **DO NOT** use this heater with a programmer, timer, separate remote-control system or any other device that switches the heater on automatically, since a fire risk exists if the heater is covered or positioned incorrectly.
- **CAUTION:** In order to avoid a hazard due to inadvertent resetting of the thermal cutout, this appliance must not be supplied through an external switching device, such as a timer, or connected to a circuit that is regularly switched on and off by the utility.
- Keep furniture, curtains and other fabric material away from the appliance.
- **DO NOT** leave the appliance unattended during use.
- From time to time, check the cord for damage. Never use the appliance if the cord or any part of the appliance shows signs of damage.
- **DO NOT** run the mains cable under carpets, rugs etc.
- **DO NOT** cover or obstruct the heater in any way. Overheating will result if it is accidentally covered.

## 1.0 IMPORTANT NOTES - CONTINUED

GB IE

- Never immerse the product in water or any other liquids.
- **DO NOT** use the appliance outdoors.
- Before cleaning the appliance, ensure it is unplugged from the power and that it is completely cool.
- **DO NOT** clean the appliance with abrasive chemicals.
- Never use accessories that are not recommended or supplied by the manufacturer. It could cause danger to the user or damage to the appliance.
- **DO NOT** insert or allow foreign objects to enter the inlet or outlet vents as this may result in electric shock, fire or damage to the appliance.
- **DO NOT** install the fire using an extension cord.
- Unplug from the mains supply if the appliance is not to be used for long periods.
- This product is only suitable for well insulated spaces or occasional use.
- **DO NOT** use this heater if it has been dropped.
- **DO NOT** use if there are visible signs of damage to the heater.
- Use this heater on a horizontal and stable surface, or fix it to the wall, as applicable.
- **WARNING:** Do not use this heater in small rooms when they are occupied by persons not capable of leaving the room on their own, unless constant supervision is provided.
- **WARNING:** To reduce the risk of fire, keep textiles, curtains, or any other flammable material a minimum distance of 1 m from the air outlet.

## 2.0 INSTALLATION REQUIREMENTS

This product is only suitable for well insulated spaces or occasional use. The appliance is supplied with a pre wired three pin plug (13 Amp fuse rated) and 1.8 meter of electrical cable. It is therefore necessary for a suitable electrical socket to be located within this distance and be easily accessible. This appliance is designed to be inset into the wall, using the wall fixtures/ fixings provided. This appliance is suitable for installation in static holiday/ park homes.

## 3.0 APPLIANCE DATA

Supply Voltage and rating power : 220-240V AC 50Hz, 1260-1500W  
 Heating Elements : 1260-1500W  
 Location : Indoor use only

Fuse Rating : 13 Amp  
 Lighting : LED (not replaceable)  
 Supply plug/cord : BS1363/1.8 metres length

This fire is fitted with LED's (Light Emitting Diode) in place of conventional bulbs. LED's generate the same light levels as conventional bulbs, but use a fraction of the energy consumed. LED's are maintenance free and will not require replacing during the life of the product.

Model	EF26-36A				
Item	Symbol	Value	Unit	Item	Unit
Heat output	Type of heat input, for electric storage local space heaters only (select one)				
Nominal heat output	P <sub>nom</sub>	1.4	KW	manual heat charge control, with integrated thermostat	N/A
Minimum heat output (indicative)	P <sub>min</sub>	N/A	KW	manual heat charge control with room and/or outdoor temperature feedback	N/A
Maximum continuous heat output	P <sub>max,c</sub>	1.4	KW	electronic heat charge control with room and/or outdoor temperature feedback	N/A

### 3.0 APPLIANCE DATA-CONTINUED

Auxiliary electricity consumption				fan assisted heat output	N/A
At nominal heat output	el <sub>max</sub>	N/A	KW	Type of heat output/room temperature control (select one)	
At minimum heat output	el <sub>min</sub>	N/A	KW	single stage heat output and no room temperature control	[no]
In standby mode	el <sub>SB</sub>	0	KW	Two or more manual stages, no room temperature control	[no]
				with mechanic thermostat room temperature control	[no]
				with electronic room temperature control	[no]
				electronic room temperature control plus day timer	[no]
				electronic room temperature control plus week timer	[yes]
				Other control options (multiple selections possible)	
				room temperature control, with presence detection	[no]
				room temperature control, with open window detection	[yes]
				with distance control option	[no]
				with adaptive start control	[no]
				with working time limitation	[no]
				with black bulb sensor	[no]
Contact details	Focal Point Fires Ltd. Christchurch, Dorset BH23 2BT				

### 4.0 UNPACKING THE APPLIANCE

Read **all** the instructions before continuing to unpack or install this appliance. Carefully remove the appliance from its packaging and lay on the floor with its back surface downward. Note: **DO NOT** stand the appliance on its frame as this may cause distortion. Check that the remaining packaging contents correlate with the component checklist below. Please dispose of all packaging with care at your local recycling centre.

### 5.0 COMPONENT CHECKLIST

QUANTITY	DESCRIPTION
1	Heater main body
1	Remote control
1	Decorative frame
1	Instruction booklet
1	Fixing kit; 4x screws 4x wall plugs
5	Magnets

### 6.0 SITE REQUIREMENTS

It should be noted that the appliance creates warm convected air currents. These currents move heat from the room surroundings to, and up the wall surfaces adjacent to the heater.

Installing the heater next to these types of wall coverings or operating the heater where impurities in the air, (such as tobacco smoke) exist, may slightly discolour wall finishing.

If the appliance is to be mounted on a dry lined or timber framed construction then the integrity and ability of the wall to carry the weight of the appliance must be confirmed. It is important in these circumstances that any vapour barrier and/or structural members of the house frame are not damaged.

If you are unsure of the ability of the wall to carry the weight and/or which type of wall fixing to use, you should take professional advice and obtain the correct fixings. Alternatively, find a more suitable wall location.

## 6.0 SITE REQUIREMENTS - CONTINUED

GB IE

### DO NOT

- mount on a ceiling or floor
- run the supply cable under carpets
- site any electrical equipment e.g. plasma screen TV sets etc, on the wall below the appliance.
- site in a position where curtains or drapes could cover the appliance, or other soft materials could cover e.g. below a coat rack
- site behind an opening door where mechanical impact/damage could occur
- site where the supply cable would become a trip hazard
- sit, stand or forcefully pull on the appliance
- obstruct, cover or force items into the openings
- use the heater to dry clothes
- site/use in an outdoor location(s)

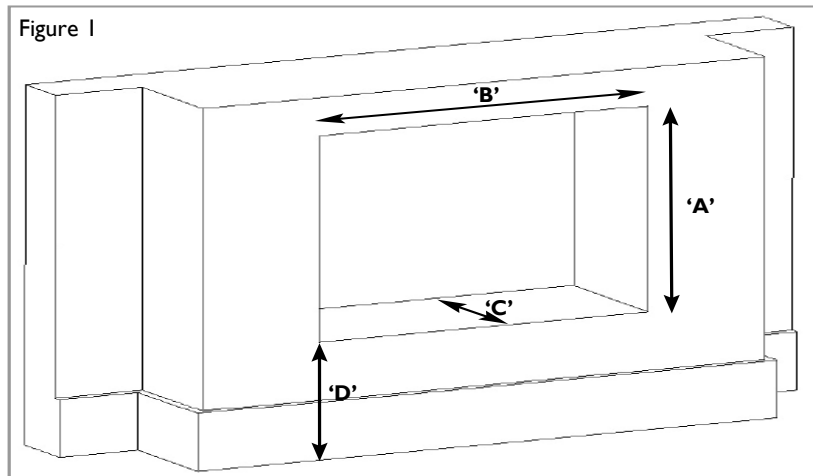

- 'A'. Opening height: 403mm - 410mm max
- 'B'. Opening width: 860mm min - 870mm max
- 'C'. Mounting depth: minimum 150mm
- 'D'. The minimum distance from the floor: 100mm

## 7.0 CLEARANCES TO COMBUSTIBLE MATERIALS

It is important that the following clearances are maintained from the appliance to combustible materials. These clearances are dependent on the mounting location as defined below:

- The minimum distance from the top of the appliance to a ceiling is 300mm
- The minimum distance from the bottom of the appliance to the floor is 100mm
- The minimum distance to the sides of the appliance is 100mm
- The minimum distance to the front of the appliance is 500mm

## 8.0 INSTALLING THE APPLIANCE

GB IE

### CAUTION: DO NOT CONNECT THE APPLIANCE TO THE ELECTRICAL SUPPLY AT THIS TIME.

Focal Point Fires Ltd. assumes absolutely no responsibility for injuries and damages that may occur due to improper installation or handling.

Remove any protective film coatings from the finished/decorative surfaces of the appliance, if any. After having selected the final mounting position of the appliance taking into account the integrity of the wall the firebox of the appliance may be secured to the wall.

To ensure customer safety, be sure to design the installation so that the strength of both the wall and any wall fixings used are sufficient. The appliance should not be installed until all wet plastering and/or dry wall sanding and wall painting has been completed. Do not block the ventilation holes of the appliance. The wall onto which the appliance is installed must be flat. Install only on a vertical surface. Avoid sloped surfaces. Installation onto anything other than a vertical wall may result in fire, damage or injury.

If the appliance is to be mounted on the inner leaf of a conventional cavity brick wall, or a solid wall, then the wall plugs and fixing screws provided may be used. Depending on the condition of the wall it may be necessary to use additional fixings. In this situation, any additional fixings and wall plugs should be of the same size and type as the ones provided.

If the appliance is to be mounted on a dry lined wall or a timber framed construction wall then efforts should be made to fix in at least two positions vertically, into one of the wooden studs, or supporting wooden members of the wall using two of the fixing screws provided. If this is not achievable then the wall should be strengthened using appropriate building materials.

If the appliance is fitted into an open chimney, the chimney must be blocked off to reduce the risk of draught and damp through the fire, which may cause the safety cut out system in the fan heater to operate.

**WARNING**

The wall where the appliance is to be installed must be capable of long-term support of the total load of the appliance. Measures should also be taken to ensure sufficient strength to withstand the force of earthquakes, vibration and other external forces. Plasterboard alone is not considered to be a structural material. It is not recommended to rely on plasterboard fixings alone to support the weight of the appliance.

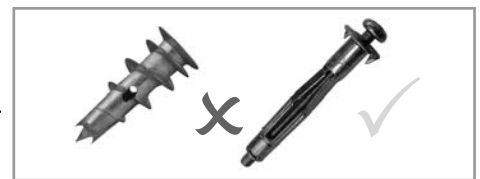

Offer the appliance into the opening to ensure a good fit and central, once in the final position, mark the positions on the wall through the 4x fixing holes with a pencil. Then remove the appliance from the opening.

Drill the wall as appropriate for the type of wall as previously described in this section, and then insert the chosen type of wall fixings into the wall.

Carefully insert the power cable through the opening and into a plug socket and ensure the plug socket is turned ON. Then place the appliance into the opening and line the holes in the bracket with the wall plugs installed into the wall.

Insert the wall fixing screws through the fixing holes in the bracket on the firebox, then screw into the 4x wall plugs using a cross headed screwdriver. Ensure the wall plugs are screwed in correctly and that the appliance is safely secured in place.

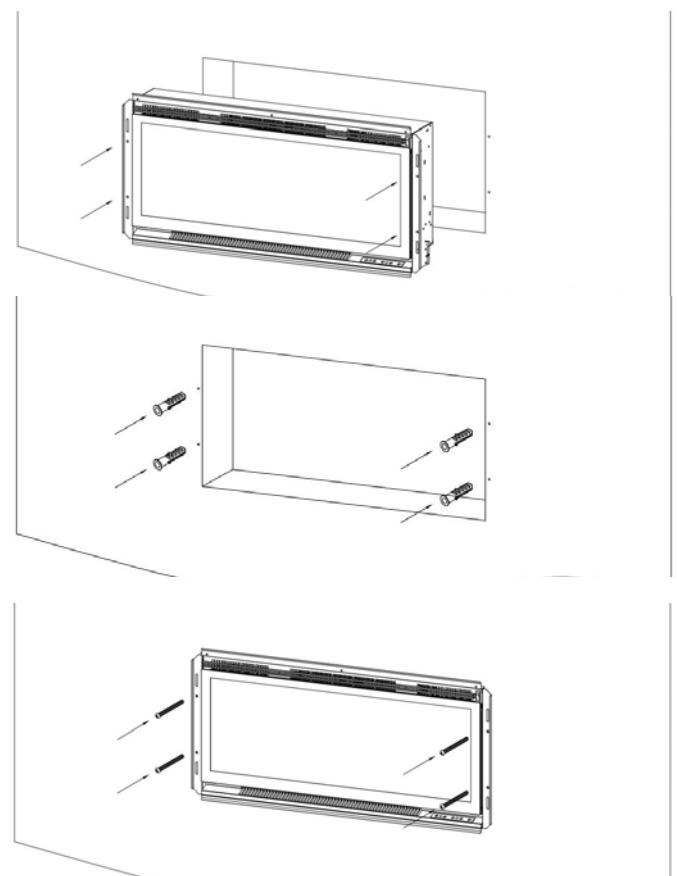



## 9.0 FITTING THE DECORATIVE FRAME

GB IE

The appliance is supplied with a decorative frame.

**IMPORTANT: Due to the possibility of sharp edges, care should be taken when handling the frame components. The use of protective gloves is recommended.**

If not pre-fitted, and the appliance is supplied with a one piece decorative frame that is to be attached to the front of the firebox. The fire front shown in these instructions may be different to the one supplied with the appliance.

### THE FRAME MUST NOT COVER ANY OF THE HEATER OUTLET!

Insert the 5x magnets onto the rear of the one piece frame as shown.

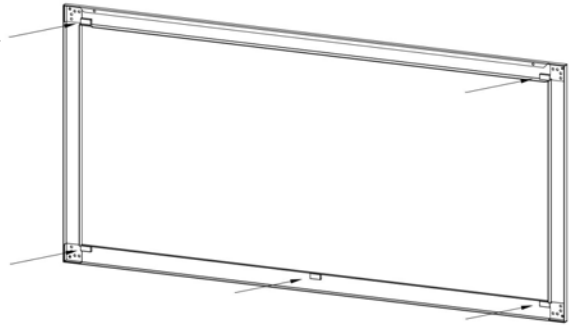

Carefully offer the one piece frame onto the top of the appliance first, then lower down at the bottom for the bottom magnets to engage with the firebox.

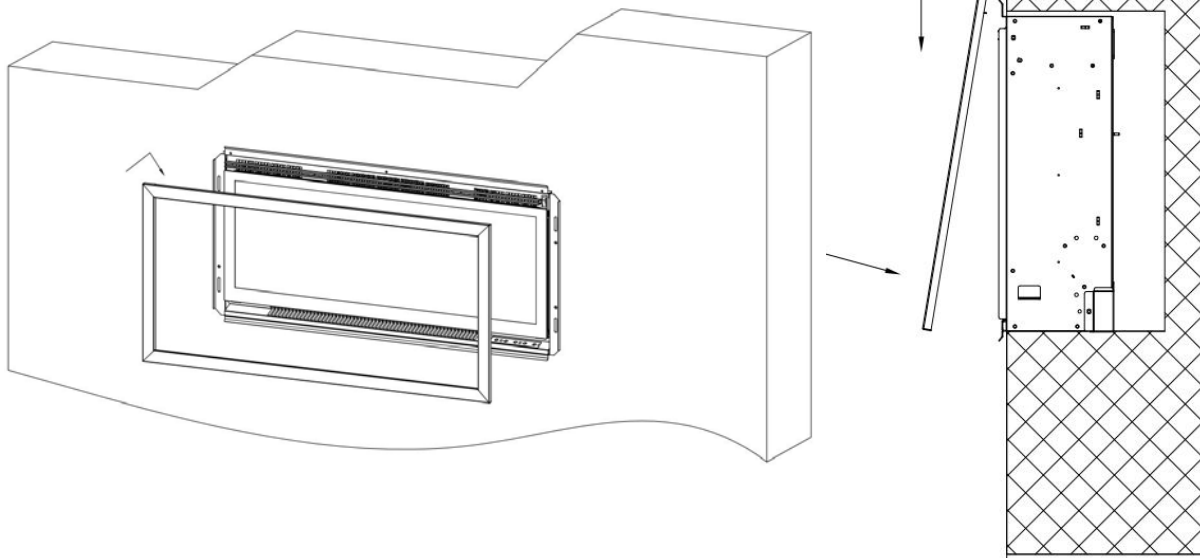

To remove the frame, carefully pull the bottom of the frame away from the firebox to break the magnetic connection, remove the magnets, then gently lower the frame back towards the firebox. Lift the frame up and away from the wall to remove the frame from the engine.

## 10.0 REMOVING THE FRONT GLASS



To remove the front glass from the appliance ensure the appliance is on standby and cool, then with a crossed headed screw driver remove the two screw from the bottom of the glass assembly.

We recommend that gloves are worn when handling glass.

Carefully lift the glass up and out of the appliance.

Carefully place the glass on a soft, clean, flat surface,

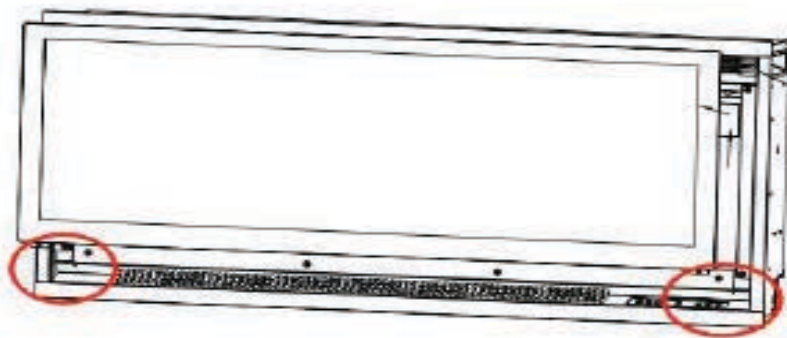

The control panel is located on the bottom right hand side of the appliance. This panel contains the buttons to operate the electric fireplace. The button functions are similar with that on the Remote Control accept if you want to adjust the temperature, you will need to press the button 5 for several seconds till the temperature indicator flashes, then press button 5 again to select the desired temperature.

## 11.0 OPERATING THE APPLIANCE

The control panel contains the buttons to operate the electric fireplace. The buttons on the control panel are located on the front, bottom right of the appliance. The remote control functions are the same as the control panel. The remote control has an effective range of up to 13 feet.

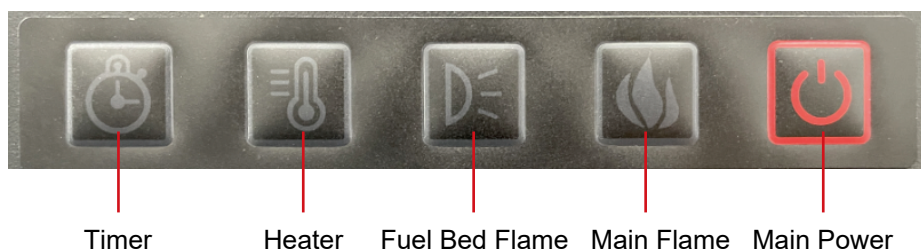

### 1. Main power

The function is the same with Keypad.

### 2. Main Flame

The function is the same with Keypad.

### 3. Fuel Bed Flame

The function is the same with Keypad.

### 4. Timer

The function is the same with Keypad.

### 5. Heater

In the mode of week timer, this button can set temperature, while in daily use it can only switch on/off heater.

### 6. "+" button

+1°C when you press this button.

### 7. "-" button

Setting of the time and week timer.

### 8. Setting button

Setting of the time and week timer.

### 9. Day button

Button to choose from Monday to Sunday or week timer mode option. Option mode: 1-2-3-4-5-6-7-A

### 10. Cancel button

The button to cancel week timer.

### 11. OK button

Run the preset mode after choosing week timer.





## 1. Control Panel and Screen

On the control panel, there are Main Power, Main Flame, Heater, Fuel Bed Flame, Timer buttons. The Display panel shows the temperature setting, the main flame setting, the fuel bed flame setting, the timer and the clock.

### (1) .Main power

Press the "Main power" button. The system default parameters: heating stalls for "82°F/ 27°C". The main flame stalls for the main flame F1, fuel bed flame C1 with no heat.

### (2) .Main Flame

Press this button to display the different Main Flame options. Main Flame options F1 → F2 → F3 → F4 → F1

Press	Display	Flame state	Main Flame setting
1st Press	F1	ON	High
2nd Press	F2	ON	Medium
3rd Press	F3	ON	Low
4th Press	F4	ON	Cycle

**When the fire is turned on and with display on, press this button for 5 seconds into the Fahrenheit temperature and Celsius temperature unit conversion, the corresponding indicator light converse accordingly, and the digital screen shows the corresponding temperature stalls**

### (3) .Heater

This button turns the heater function on/off and "+" "-" to select the temperature: →17°C→18°C→19°C→20°C→21°C→22°C→23°C→24°C→25°C→26°C→27°C→ON

<1> Press this key to turn on the heating function. Press this button for 3 seconds to select the temperature. The temperature display window will flash. When the temperature is set, the display unit will flash 10 times, save the setting automatically and exit the setting state. When the display unit is turned on, the setting status is also exited if there is no operation within 10 seconds.

<2> Fan delay function: fan shut down after heating stop working for 15s.

<3> Open window detection: While at heating status, open a window at the room for 30 minutes, the fire will automatically alarm "OP", if the alarm is not eliminated within 30 minutes, the fire will be turned off automatically. When the "OP" alarm occurs, you can press "Heater" for 3 seconds or turn off the fire then turn it on to eliminate the alarm.

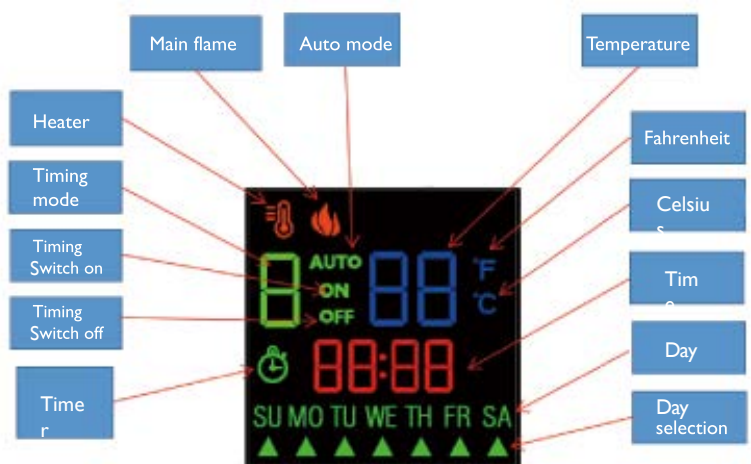

## (4) Fuel Bed Flame

Press this button to display the different fuel bed options. Fuel bed options C1→C2→C3→C4→C1

### Fuel Bed Flame setting

Press	Display	Fuel Bed Flame Setting
1st Press	C1	High
2nd Press	C2	Medium
3rd Press	C3	Low
4th Press	C4	Cycle

## (5) .Timer

Press Timer button to set the time, each press would be additional 1 hour, (can not enter week timer, only to set the current automatic switch off time. In the week timer mode this button is closed)

Timer range: 1H→2H→3H→4H→5H→6H→7H→8H→9H→OF→1H (cycle)

## Clock and week timer settings

### A.Clock setting

1. At standby state (after the unit is plugged in and before pressing "Main power"), press the Setting button on the remote control for 3 seconds, or press the Timer button on the machine keypad for 3 seconds, the digital display would be "00:00" flashing.

2. Press "+" on the remote control (or press the Main Flame button on the keypad) to set hour, press the remote control "-" (or press the Heater button on keypad) to set minute.

3. Press "Setting" (or press "Timer" on keypad) to enter setting of the week timer. Press "Day button" (or press "Main Flame" on the keypad) to select Sunday, Saturday. When finished, press "Setting" (or press "Timer" on the keypad) to exit setting.

4. After the initial power on, you need to set the clock, otherwise the clock will remain "00:00" status and you can't set week timer function.

5. After you turn on the power, the clock will automatically light up, the clock automatically turn off after 60s, you can press any one button to wake up the clock, and the clock will automatically turn off after 60s again.



**A**

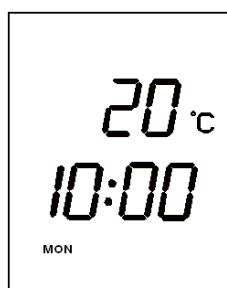





**B**

### B.Heat setting

1. Use remote control's Heater button to select temperature →17C→18C→19C→20C→21C→22C→23C→24C→25C→26C→27C→ON

## C. Timing switch on/off preset

1. While the fire is working, press "Setting"  to preset timing switch on/off the week timer. Press  to enter mode 1, while the display is 1 ON, the clock will be "01:00", press "+" to set hour, press "-" to set minute, press  to set week, every press on the  will show SU, MO, TU, WE, TH, FR, SA and flash in turn., you can use the "+" key to select the desired day and use "-" to remove the desired day,  shows all of the days selected.

Press "Heater" to enter temperature setting, then press "+" "-" button to set temperature. After setting, press "OK" button to save setting and return to clock interface.

2. Press "Setting" again to set timing switch off, the display is 1 OFF, the clock is displayed as "02:00", press "+" to set hour, press "-" to set minute, the date of the timer off keeps the same with the timer on, you can't change it manually. After setting, press the "OK" button to save setting and return to clock interface or press "Setting" button to enter setting of mode 2, which operation is the same with mode 1. You can set mode 1 to mode 7 with the above method.

3. After the preset timing on/off switch, you can use Day button to select the desired timing mode 1-2-3-4-5-6-7-auto option, after the option shows 10 seconds without any operation, it will save the selected option and enter the current setting of the option, the timer logo of the display lightens and will automatically run the preset switch setting program.

You can individually select each setting of modes 1-7 for automatic on/off switching, or you can preset the desired settings, and then select "auto mode" for multiple preset series executions.

4. If you want to set the on/off switch and temperature setting for different periods of the week, then set the switching time and temperature of each day from Sunday to Monday in mode 1-7. After setting, press the "OK" button and the system will run the week timer of 1-7 modes. You can also set 1-7 modes within 1 day, use "auto mode" to run timing switch on/off within 1 day. Be aware that when you use "auto mode", you need to make sure the settings of times does not overlap each other, otherwise the timer can go wrong.

5. After entering the set time, you can press "Cancel" button  to exit week timer mode.

6. You can check the 1-7 timer settings by pressing the "Setting" button. For example, press the "Setting" button to display (1 ON "01:00" temperature 27C), press the "Setting" button again to display (1 OFF "02:00" temperature 27C).

Press the "Setting" button again to display (2 On "03:00" temperature 26C) ..... then press the Setting button to display (7 OFF "13:00" temperature 27C). While displaying, you can adjust setting according to step 1 and step 2. While the fire is at week timer status, you can't adjust setting of time and temperature.

## 12.0 SAFETY CUTOUT SYSTEM

GB IE

This product has one non-self-resetting overheat protection device (thermal cut-out) which will activate if the air inlets or outlets are obstructed. For safety reasons the fire will NOT switch on again automatically, the following procedure must be carried out before the fire can be operated.

NOTE: The visual effect will remain operational if the cutout is activated, only the fan heater is prevented from working.

Switch OFF the appliance **at the wall socket or outlet**. Leave the fire OFF for a period of no less than 10 minutes, ensuring all obstructions are removed. Switch the appliance ON **at the wall**. Ensure the appliance is turned ON at the control switches. If the fire fails to operate correctly, repeat the above procedure. If an attempt to switch on the appliance is made before the safety cutout has reset, the appliance may cutout for a further period of time. If the sequence has been followed correctly and the appliance still fails to function, check the fuse in the wall outlet. If this is not the cause, call an electrician or maintenance engineer.

## 13.0 CLEANING AND MAINTENANCE

### ALWAYS DISCONNECT THE APPLIANCE FROM THE MAINS SUPPLY OUTLET SOCKET BEFORE UNDERTAKING ANY CLEANING OR MAINTENANCE!

For general cleaning use a soft clean duster - never use harsh abrasive or cleaners. The glass viewing screen should be cleaned carefully with a soft cloth.

If in doubt consult a qualified electrician. Refer to Section 3.0 Appliance Data for fuse specification. Excluding fuses, use only genuine manufacturers spare parts available from your supplier.

#### Replacing the remote control battery:

When the battery becomes weak, the range of the remote control becomes shorter. Replace them with two AAA batteries.

Note: Keep the battery out of the reach of children.

## 14.0 SERVICING

#### There are no internal user serviceable parts.

Check regularly for security of wall fixings as appropriate. Also check security of supply cable and connections. If the supply cable becomes damaged, it must be replaced by a service agent or competent person, such as a qualified electrician.

This appliance is supplied with a BS1363 3 pin plug fitted with a 13 Amp fuse. Should the fuse require replacing, it must be replaced with a fuse rated at 13 Amp and approved to BS1362. In the event of the mains plug being removed/ replaced for any reason, please note : **IMPORTANT:** The wires in the mains lead are coloured in accordance with the following code:

Blue - Neutral

Brown - Live

Green/ Yellow - Earth

As the colours of the wires in the mains lead of this appliance may not correspond with the colour markings identifying the terminals in your plug, proceed as follows. The blue wire must be connected to the terminal marked with an N or coloured black. The brown wire must be connected to the terminal marked with an L or coloured red. The green/yellow wire must be connected to the earth terminal which is marked with an E or with the earth symbol. **WARNING:** Never connect live or neutral wires to the earth terminal of the plug.

NOTE: If a moulded plug is fitted and has to be removed take great care in disposing of the plug and severed cable, it must be destroyed to prevent engaging into a socket.

Refer to Section 3.0, Appliance Data for fuse specification. Excluding fuses, use only genuine manufacturers spare parts available from your supplier.

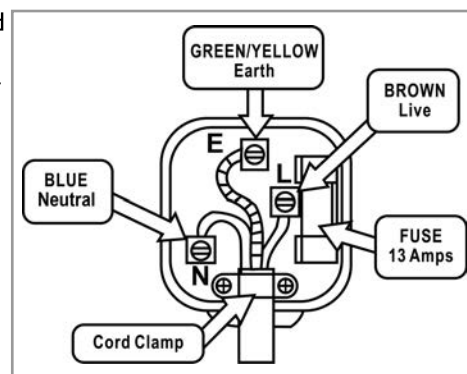

<b>My electric fire</b>	<b>Remedy</b>
is not switching on	Ensure mains switch is on. Replace the fuse in the plug.
is not emitting any heat	The fire is fitted with an energy saving thermostat. If the temperature in the room is higher than the temperature selected on the fire, then the thermostat will stop the heater from turning on. For example, if the room temperature is 22°C or above and the fire's heater is set at 22°C, then the heater will not be required until the room temperature drops below 22°C. If this is the case select a higher temperature setting than the room's temperature and the heater will begin to operate. The safety cut-out may have been operated. Switch the appliance off, leave for 10 minutes then switch back on.
shuts off after a period of time	Check that the temperature is not set onto the lower settings. If the room is warm enough the thermostat will stop the fire switching the heat on.  Check that the air inlet/outlet is blocked off.  Check that the window detection sensor has not activated.
remote control is not operating	Check or replace batteries.
display panel shows	<p><b>88</b> There is a fault with the heater. Check that the temperature is not set onto the lower settings. If the room is warm enough the thermostat will stop the fire switching the heat on. Check that the air vents and heater outlets are not blocked off.</p> <p><b>EE</b> There is an electrical fault. A service engineer will need to check the thermostat for any loose connections.</p> <p><b>OP</b> The open Window Detection function is in operation, this operates when the appliance is heating and the ambient temperature suddenly drops <math>\geq 5^{\circ}\text{C}</math> within 10 minutes, and the environment cannot be warmed up within 30 minutes, resulting in the appliance automatically displaying "OP." The heating function will then be automatically turned off, and when the "OP" is displayed, it can be turned off and then restarted by turning off and on the appliance to clear the fault code.</p>

## 16.0 GUARANTEE - TERM AND CONDITIONS

### 3 Year Guarantee Terms and Conditions

#### Registration is not required.

The 3 year guarantee only covers products purchased on or after 1st February 2009. The 3 year guarantee commences from the date of purchase, provided that the following 3 terms and conditions are adhered to:

1. For any claim to be made within the 3 years from date of purchase you will be required to provide and supply us with your proof of purchase.
2. Your gas fire must have been commissioned by a Gas Safe registered installer, evidence of which you must provide together with the Gas Safe registration number.
3. Your appliance must have been serviced annually, irrespective of use, by a Gas Safe registered installer, evidence of which must be provided, such as the receipt.

Please note all consumable items such as any ceramics including coals, pebbles, matrix, front strips, panels and bulbs are not covered by the 3 year guarantee.

We reserve the right to reject any claim or make a charge for any visit where the cause of the defect is due to non-compliance with the installation and/or servicing instructions or misuse of the appliance.

If a repair is chargeable during the warranty period, we will inform you and where possible, provide a quote or price guide before starting work. We cannot always give a firm cost until we commence the repair as it is not always possible to identify which components have been damaged.

Repaired or replaced products are covered only for the remainder of the original guarantee period and the guarantee period will not be extended even if we repair or replace any product or part.

If we replace any component or product, the component or product removed will become our property.

We will not accept or reimburse the cost(s) of any third party who undertakes any work carried out on the product or fits parts, unless we have approved such work in advance of it being carried out.

The Manufacturer's guarantee does not apply to:

- Damaged caused by faulty installation, theft, tampering, neglect, misuse, normal wear and tear, accident, fire, flood, explosion, lightning, storms, frost or other bad weather conditions.
- Damage caused by the non-observance of the Manufacturer's Installation Instructions.
- Any unauthorised adjustments made to the product by a third party.
- Servicing and its associated costs.
- Self-maintenance tasks such as cleaning.

### **Making a claim is easy.**

If you wish to make a claim under our 3 year guarantee, and all of the terms and conditions for your product have been met then please submit the following information for the attention of the 3G Service Department to [3g@focalpointfires.co.uk](mailto:3g@focalpointfires.co.uk). Alternatively, you can fax to 01202 499326 or post to Focal Point Fires, 3G Service Department, Reid Street, Christchurch, Dorset, BH23 2BT. Please note that this does not affect your statutory rights.

### **Details required:**

1. Name, full address (including post code) and contact telephone numbers.
2. Receipt of purchase or credit card statement.
3. Original installer's Gas Safe\* registration number (gas fires only).
4. Annual service receipt for every 12 months (gas fires only).



This product complies with conformity requirements of the applicable European Regulations or Directives.



This product complies with conformity requirements of the applicable UK Regulations.



Waste electrical products should not be disposed of with household waste. Please recycle where facilities exist. Check with your local authority or retailer for recycling advice. As our policy is one of continuous improvement and development, we therefore hope that you will understand we must retain the right to amend details and/or specifications without prior notice.